

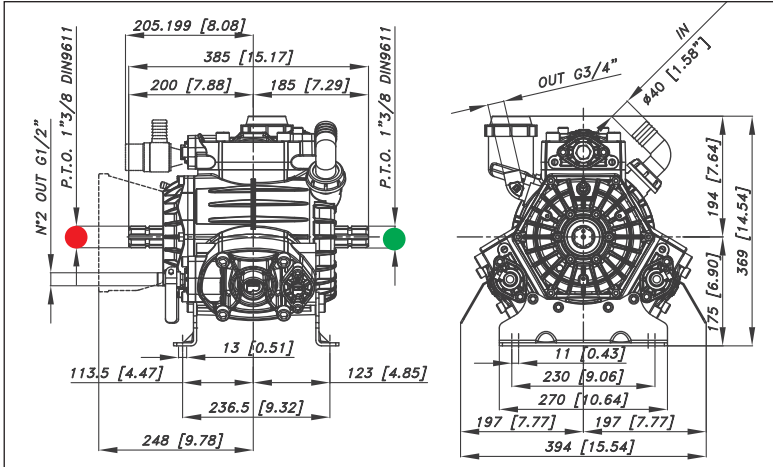

PBO Series 1100 - 1250

Pompa a 3 membrane-pistone semidrauliche.

Three piston semi-hydraulic diaphragm pump

Мембранно-поршневой насос с 3 полугидравлическими узлами.



Optional - Optional - По заказу   

Caratteristiche tecniche

Specifications

Технические характеристики

g/min; R.P.M.; об/мин;	g/min.	R.P.M.	550	550	
Peso - Weight - Вес	Kg	lb	25,3	55,6	
Dislivello aspirazione Negative pressure Перепад уровня при всасывании	MAX	mt	ft	1,5	4,9
	Servizio discontinuo Discontinuous service - Прерывистая работа	mt	ft	3	9,8
Ø Aspirazione - Ø Intake - Ø Вход	830	mm	in	40	1" 9/16
Ø Mandata - Ø High pressure - Ø Выход		mm	in	6, 3/4	6, 3/4
Max. Temperatura - MAX Temperature - Макс. Температура		°C	°F	60	140
Tipo olio - Oil type - Тип масла	SAE	W	30	30	
Capacità olio - Oil capacity - Объем масла	lt	U.S.G.	1	0,26	

ALBERO POMPA - PUMP SHAFT - ВАЛ НАСОСА



● ANT. - FRONT - ПЕР.



● POST - REAR - ЗАД.

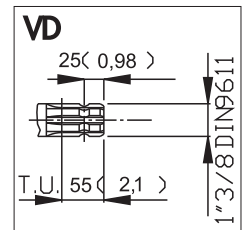
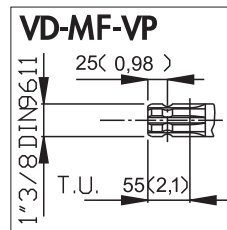

ACCESSORI - ACCESSORIES - АКССУАРЫ



ACCESSORI D'AZIONAMENTO
DRIVE ACCESSORIES

Pag. 105

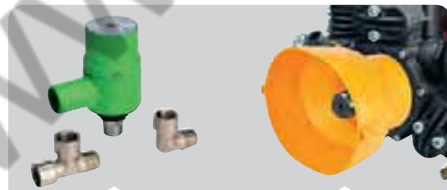

DISPOSITIVI DI SICUREZZA
SAFETY ACCESSORIES

Pag. 106



Pag. 106



FILTRI
FILTERS

Pag. 107

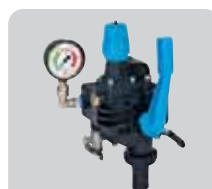

GRUPPI DI COMANDO
CONTROL UNITS

Pag. 92



COMPUTER E PANNELLI
COMPUTERS AND SPRAYERS CONTROL

Pag. 150



● POST - REAR - ЗАД.



● POST - REAR - ЗАД.

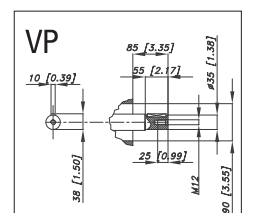
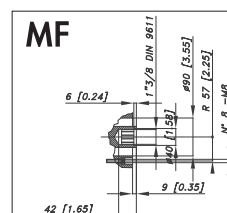

PBO Series

PBO 1100

37.5065.97.3 - VD
37.5066.97.3 - MF
37.5067.97.3 - VP



110 29,1
l/min USGPM



50 725
bar P.S.I.



TABELLA RENDIMENTI - PERFORMANCE CHART
ТАБЛИЦА ПРОИЗВОДИТЕЛЬНОСТИ

g/min R.P.M. → об/мин;	400		450		500		550	
	L/min USGPM	KW HP	L/min USGPM	KW HP	L/min USGPM	KW HP	L/min USGPM	KW HP
2	80	0,3	90	0,4	100	0,4	110	0,4
29	21,1	0,4	23,8	0,5	26,4	0,5	29,1	0,6
20	79	3,1	88,9	3,5	98,7	3,9	108,6	4,3
290	20,9	4,1	23,5	4,7	26,1	5,2	28,7	5,7
40	77,9	6,1	87,6	6,9	97,4	7,6	107,1	8,4
580	20,6	8,2	23,2	9,2	25,7	10,2	28,3	11,2
50	77,1	7,6	86,7	8,5	96,4	9,5	106	10,4
725	20,4	10,1	22,9	11,4	25,5	12,6	28	13,9

PBO 1250

37.5111.97.3 - VD
37.5112.97.3 - MF
37.5113.97.3 - VP



125 33
l/min USGPM



50 725
bar P.S.I.



TABELLA RENDIMENTI - PERFORMANCE CHART
ТАБЛИЦА ПРОИЗВОДИТЕЛЬНОСТИ

g/min R.P.M. → об/мин;	400		450		500		550	
	L/min USGPM	KW HP	L/min USGPM	KW HP	L/min USGPM	KW HP	L/min USGPM	KW HP
2	90,9	0,4	102,3	0,4	113,6	0,4	125,0	0,5
29	24,0	0,5	27,0	0,5	30,0	0,6	33,0	0,7
20	89,5	3,5	100,6	4,0	111,8	4,4	123,0	4,8
290	23,6	4,7	26,6	5,3	29,5	5,9	32,5	6,5
40	88,0	6,9	99,0	7,8	110,0	8,6	121,0	9,5
580	23,2	9,2	26,2	10,4	29,1	11,5	32,0	12,7
50	87,3	8,6	98,2	9,6	109,1	10,7	120,0	11,8
725	23,1	11,4	25,9	13,9	28,8	14,3	31,7	15,7